

ooni

# Ooni Karu Essentials Guide

How to set up, use and look after Ooni Karu, plus handy tips and recipes.



## Important



Your safety is paramount. Please read the Ooni Karu safety manual carefully.



Ooni Karu is designed for outdoor use only. Do not fire in high winds.



Ooni Karu has been designed to run at up to 932°F (500°C). If Ooni Karu exceeds these temperatures, stop adding fuel and allow to cool.



Keep Ooni Karu company while preheating and cooking. It must not be left unattended while lit.



Ensure children and pets are kept at a safe distance and supervised at all times around Ooni Karu.



Ooni Karu will get hot. Do not touch the outer shell while in use.

# Contents

<b>Say hello to Ooni Karu</b>	2	<b>Flame management</b>	22
<b>Getting the most from Ooni Karu</b>	4	<b>Top tips for making great pizza</b>	24
<b>Ooni Karu features</b>	6	<b>Top tips for launching pizza</b>	26
<b>What's in the box?</b>	8	<b>Recipes</b>	
<b>Tools for cooking</b>	10	Ooni Classic Pizza Dough	28
<b>Which fuel should you use?</b>	12	Ooni Classic Pizza Sauce	30
		Pizza Margherita	32
		Rosemary Chicken with Roasted Onions	34
<b>Chimney vent</b>	14	<b>Care instructions</b>	36
<b>Cooking with...</b>		<b>Troubleshooting</b>	38
Wood	16	<b>Keep in touch</b>	43
Charcoal	18		
Gas	20		

## Say hello to Ooni Karu!

Everyone deserves great pizza, and that's why we launched Ooni Karu on Kickstarter in 2019. Thanks to backers from around the world supporting this product, you can enjoy delicious meals cooked with fire in this awesome portable, wood- and charcoal-fired pizza oven.

We put this Essentials Guide together to help you to get the most out of Ooni Karu. Have a read, prepare your ingredients and then invite your friends and family to join you - the way you cook and enjoy food outdoors is about to change forever.

Ooni Karu is powered by real wood and charcoal, with a portable design and powerful flames and heat retention once lit. If you prefer to cook with gas, simply attach the Ooni Gas Burner\* so you can fire up with propane and achieve those same high heats. Ooni Karu heats to 932 °F (500 °C) and is ready to start cooking awesome pizza in just 10 minutes – create authentic Neapolitan-style pizza, plus incredible steak, delicious roasted vegetables and more.

Like all Ooni products, cooking with Ooni Karu is simple, fun and unique. Whether you're a beginner or pro, the Essentials Guide will help you to enjoy the Ooni Karu experience. Be sure to hold onto this guide for hints, tips and delicious recipes.

Thank you for being part of the Ooni Community and enjoy Ooni Karu - we know you're going to love it.



Kristian and the Ooni Team

*\*available via ooni.com. Region dependent.*



1% of Ooni's global turnover is actively managed for charitable causes and positive social and environmental change through the Ooni Impact Fund. So far we have planted tens of thousands of trees and we're a member of 1% for the Planet.

[ooni.com/impact](https://www.ooni.com/impact)

# Getting the most from Ooni Karu

**Before you get fired up and cooking, read through your Manual and Safety Instructions and store them for future reference.**

! Ooni Karu is for outdoor use only. Do not fire in high winds.

**Before you cook**  
Before you cook for the first time, run Ooni Karu at top temperatures for at least 30 minutes. Allow the oven to cool and wipe the inside with dry paper towels. This process is called seasoning and it will burn off any oils or coatings that are remnants from the manufacturing process.

Take this time to familiarise yourself with the features of Ooni Karu. Now you're ready to invite friends and family over for the best pizza they've ever had.

Using suitable fuel is the first step towards delicious food. When you fire up with high-quality fuel, you will get

amazing food out. *See page 12 for further information.*

When cooking with the Gas Burner, check the connections on the propane tank, hose and regulator. They should be secured and checked for leaks before every cook.

Place Ooni Karu on a table sturdy enough to hold the oven and your ingredients. Wooden and stone surfaces are recommended; glass and plastic surfaces are not. If you want to change from using solid fuels to using the Gas Burner while cooking, it's essential to allow Ooni Karu to cool first before attaching the Gas Burner.

**Cooking**  
Ooni Karu has been designed to run at up to 932°F (500°C). If your oven exceeds this temperature, simply stop adding fuel. You can also remove the hatch to lower the temperature.

If you are taking a break from cooking, give Ooni Karu a rest too – stop adding fuel or switch off the Gas Burner.

Everybody loves 60-second pizza, including children! Pizza is a great way to get them involved in prepping dinner. Remember to supervise children at all times and to keep them and pets at a safe distance while Ooni Karu is hot.

Before attempting to move or clean Ooni Karu after cooking, wait for at least 1 hour after extinguishing. Store when Ooni Karu is completely cool and dry. Never use water to cool down or extinguish Ooni Karu.

**Learn more**  
We have a passionate community of Ooni owners from around the world at [community.ooni.com](http://community.ooni.com) who are constantly innovating and creating amazing dishes. You can also find delicious recipes, video guides and inspiration at [ooni.com](http://ooni.com). If you have any questions - or want to send us some photos of your dishes - reach us at [support@ooni.com](mailto:support@ooni.com)

We love hearing from you and are always happy to offer advice, recipes and more.

*Excited to get cooking? Skip to pages 16-20 for lighting instructions.*



## Ooni Karu features



### Wood and charcoal

Ooni Karu needs good airflow to reach optimum temperatures. When firing with solid fuels, set up with at least 3 feet (1 metre) of space around the oven for proper airflow. Remember to remove the chimney cap and leave the door on for optimum performance.



### Gas

Remove the chimney and door when cooking with gas. You can add the chimney cap to the oven body to create a seal.

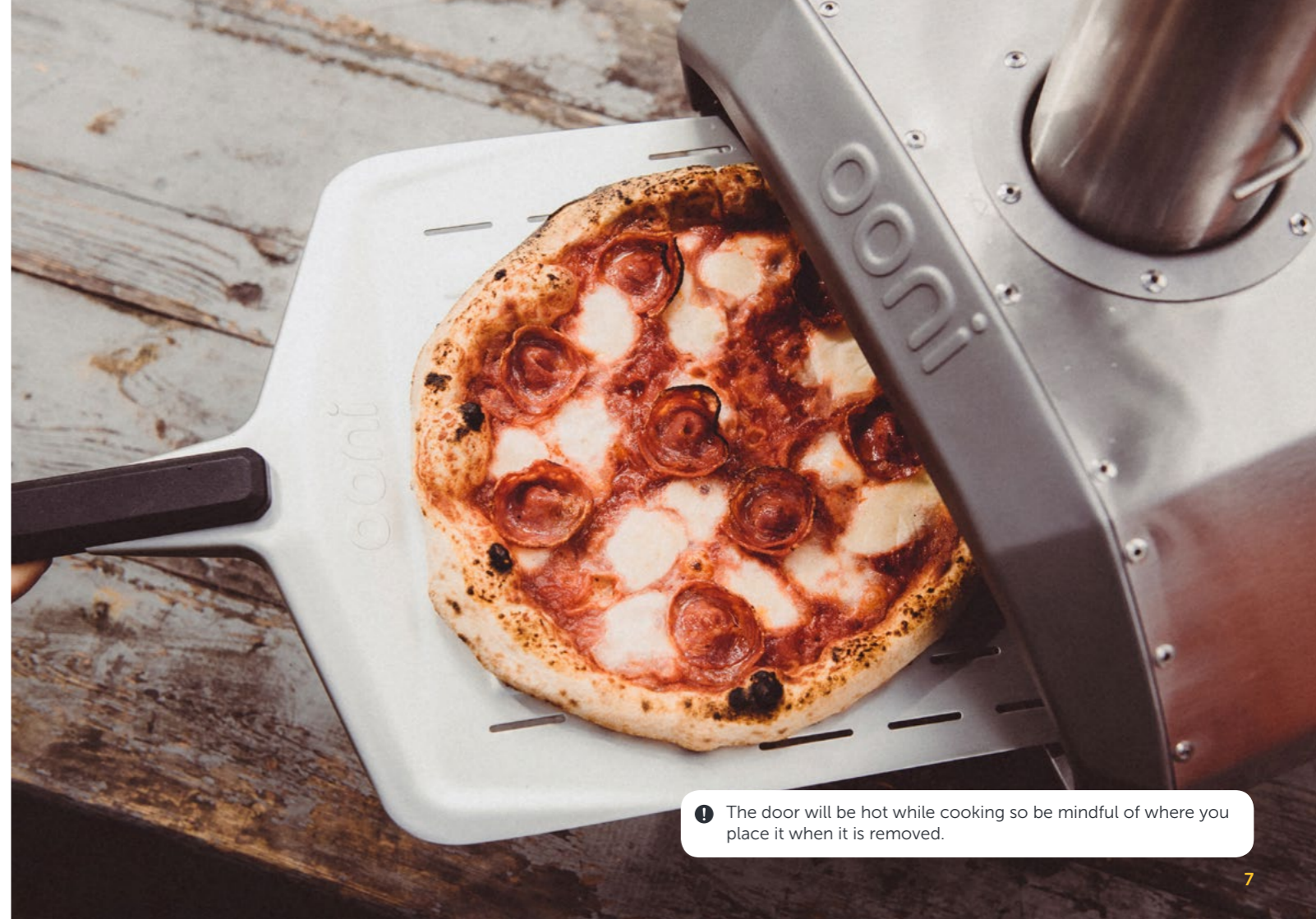

ⓘ The door will be hot while cooking so be mindful of where you place it when it is removed.

# What's in the box?

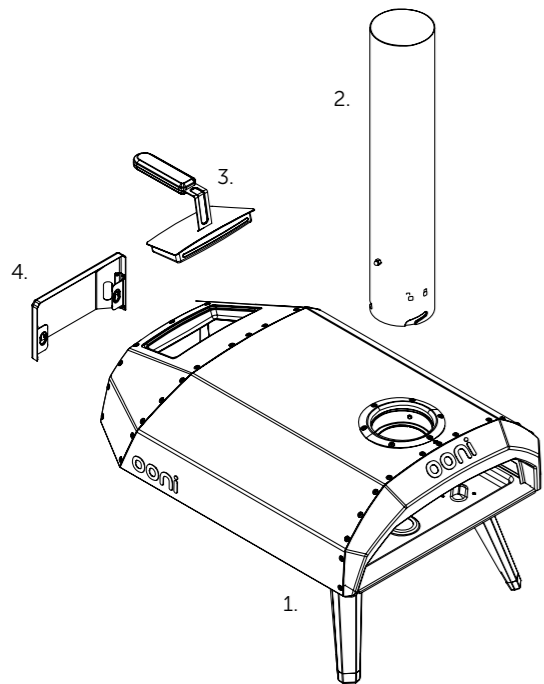

## 1. Main body

Fully insulated to help Ooni Karu run efficiently and retain heat. Ooni Karu has three legs that keep it sturdy and safe and non-slip feet to protect your table-top surface.

## 2. Chimney

Draws heat through Ooni Karu when cooking with wood and charcoal. The chimney's quick release feature allows you to set up and pack down with ease.

The chimney vent controls the total airflow through the oven body and can be adjusted while wearing heat resistant gloves. *See page 14 for more information.*

## 3. Fuel hatch

Fully insulated to hold in heat. Remove when adding wood and charcoal to the burner.

## 4. Rear vent cap

Covers the rear of Ooni Karu when cooking with wood or charcoal to control flames.

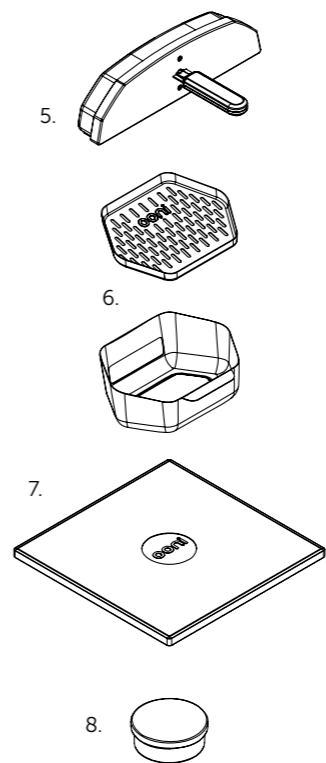

## 5. Door

Thick and fully insulated to retain heat, with a cool-to-touch handle. **The door must be off when cooking with gas.**

! The door will be hot while cooking so be mindful of where you place it when it is removed.

## 6. Burner

Carefully designed to help Ooni Karu reach optimum temperatures when firing with wood and charcoal. The holes in the grate serve a dual purpose: to increase airflow through the fuel and to allow excess ash to drop away from the burning area.

## 7. Stone baking board

Custom-made from durable cordierite stone, the stone baking board retains heat and cooks pizza bases perfectly.

## 8. Chimney cap

Keeps rainwater out of Ooni Karu when not in use. This doubles as a seal for Ooni Karu when the chimney is removed for gas-fired cooking.

## Tools for cooking



### Ooni Infrared Thermometer

Get an instant and accurate temperature reading by aiming the laser at the middle of the stone baking board. The Ooni Infrared Thermometer is the must have tool for gauging the temperature of the stone baking board before you begin cooking. It will allow you to achieve the perfect pizza base. We aim for 752°F (400°C) when baking Neapolitan pizza.



### Ooni Pizza Peels

Our pizza peels have been designed specifically for use with Ooni pizza ovens and are sleek and easy to transport and store. Having an additional peel helps to speed up the pizza supply chain, allowing you to invite more friends and family to create their own personalised pizza. We make our peels in perforated aluminium and wooden options. Ooni Karu is compatible with a maximum of 12" peels



### Ooni Cast Iron series

The high temperatures and fuel versatility of Ooni Karu are perfect for searing meat, baking fish and roasting vegetables. Our Ooni cast iron series is designed to withstand the high temperatures of Ooni ovens, made with removable handles and fitted wooden boards for easily moving and serving of your hot dishes.



### Ooni Pizza Oven Brush

A 2-in-1 stone baking board brush and scraper tool, this will help you clean your Ooni efficiently and quickly – use it to brush off excess flour with the bristles, then flip it over to scrape away fallen food.



Check out [ooni.com](https://www.ooni.com) for recipe inspiration.

# Which fuel should you use?

Ooni Karu has been designed for use with solid fuels, including real wood and charcoal, as well as propane gas with the use of the Gas Burner accessory. Whichever fuel you choose, Ooni Karu will cook incredible dishes.

! Never use water to clean the grate.

Note that Ooni Karu preheats super quickly and will heat most efficiently when topped up with fuel gradually, which creates the best environment to allow for proper airflow. Top up little and often to maintain consistent temperatures. Solid fuels should never overflow out of the grate and the fuel hatch should always be able to fit in place and close comfortably.

Before you cook, use a hard-wearing brush to clean any excess ash or fuel residue from the grate so that the air can flow through the perforations.



Cooking with fire is as much an art as it is as a science – the following table will give you an idea of the results to expect from each fuel:

Fuel	Temperature	Benefits
Charcoal & Wood	Up to 932°F (500°C)	Lighting a base layer of charcoal keeps a steady, even temperature; adding wood will give a burst of heat and wood-fired flavor, which is perfect for pizza.  <i>See page 16 for lighting instructions.</i>
Wood	Up to 932°F (500°C)	Cooking with wood alone is the fuel of choice for Neapolitan pizza purists. Wood is also ideal for any food that enjoys a fast cooking time, such as steak, fish and vegetables.  <i>See page 16 for lighting instructions.</i>
Charcoal	Up to 932°F (500°C)	Bake amazing bread, meat and more with charcoal. We love the option for low and slow cooking with charcoal and it gives you the option to bake thicker-crust and deeper-dish pizza. Charcoal will give a base temperature without excess flame.  <i>See page 18 for lighting instructions.</i>
Gas **	From 482-932°F (250-500°C)	For cooking with ultimate speed and reaching super high temperatures very quickly, use the Ooni Gas Burner to create the ideal temperature for cooking pizza and so much more.  <i>See page 20 for lighting instructions.</i>

\* Please note that the above figures are estimates and are dependent on weather and ambient temperatures.

\*\* Gas Burner available at ooni.com. Region dependent.



## Chimney vent

The easiest way to regulate temperature in Ooni Karu is through fuel management. The inbuilt chimney vent also allows for adjustments to be made to airflow and heat distribution through the oven.

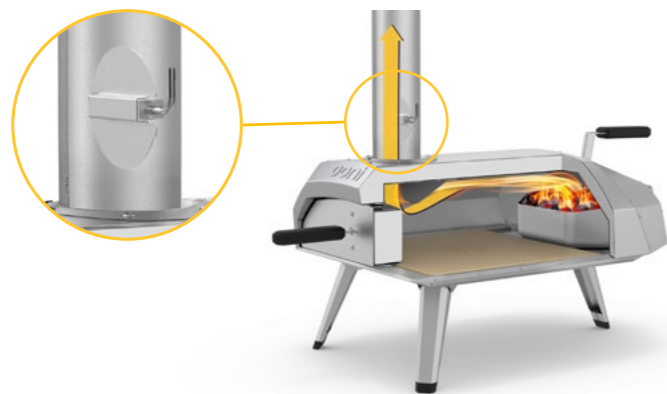

**Open chimney vent** - increases the draw of air through the oven, creating more powerful flames and an increased heat.

If your Ooni Karu is not running hot enough on wood or charcoal, check that your chimney vent is open and chimney cap is removed. This will provide maximum airflow and top temperatures through the oven.

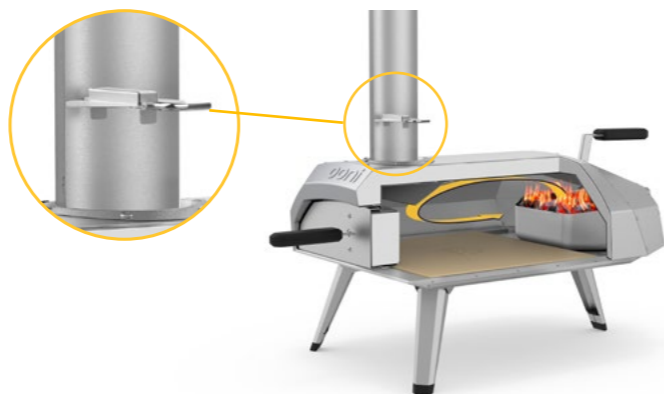

**Closed chimney vent** - reduces the draw of air for a smokier effect and a lower heat.



Are your pizza toppings cooking faster than the pizza base? Simply close the chimney vent to bring down the flames, which gives the pizza base more time to cook.



# Cooking with wood

The sounds of crackling wood and the incredible smell of a wood-burning fire make for a really sensory cooking experience and add wood-fired flavor to food. We recommend cooking with 100% hardwood, which create powerful rolling flames.

## Types of wood

Always use kiln-dried hardwood for the best results. Beech and oak are our favourite to use in Ooni Karu.

*Do not use treated or painted wood. Wood with high resin content, such as pine or spruce, might add unwanted flavours to your cooking.*



1. Start with 3-6 pieces of wood in your grate and light with natural firestarters. You can also light with a blowtorch.



2. Refuel when the wood has mainly burnt to embers but before all visible flames have disappeared.



3. Add fuel little and often and do not overfill - wood must not overflow the grate.

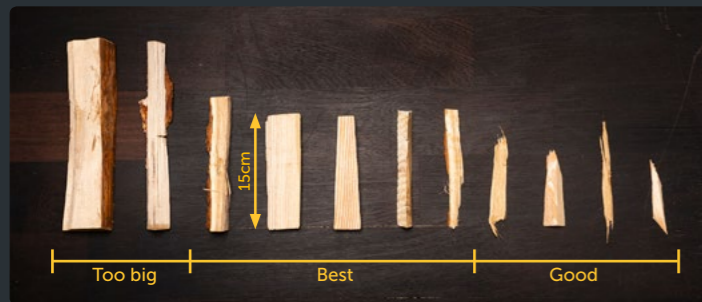

## Size

We recommend pieces of wood approximately 15cm (6").



It is normal to see smoke when cooking with wood. Ooni Karu will burn cleanly and with minimal smoke when running at optimum temperatures.

# Cooking with lump charcoal

Lump charcoal offers a wide range of temperatures and is an easy choice for low and slow cooking in Ooni Karu. We use charcoal for non-pizza dishes that do not need the same exposure to flame.

Use good quality, sustainably sourced lump charcoal like Ooni Premium Lump Wood Charcoal.

Lump charcoal will burn down to a small amount of ash, reducing your clean-up.

*Do not use briquettes as they will block the holes in the grate, resulting in reduced airflow.*



**1.** Start with 2-3 pieces of charcoal in your grate and light with natural firestarters.



**2.** Ooni Karu is not ready to cook when the charcoal is black and producing smoke.

When your charcoal is glowing white with red centre, it is ready to cook.



**3.** Top up little and often to maintain a good base temperature. Always leave room for airflow through the grate.



A combination of charcoal and wood is a great way to cook in Ooni Karu. You can achieve a steady base temperature with lump charcoal and adding wood gives a burst of heat and wood-fired flavour.

# Cooking with gas

The most important factor in cooking awesome pizza is the intense heat. Our Gas Burner provides that heat and allows you to watch while your pizza cooks, as cooking with gas must always be done with the door off.

## Type of gas

The Ooni Gas Burner has been designed to run on propane gas.

Please refer to your Ooni Gas Burner manual for more information on which type of gas connection. Connection types can vary from country to country.

## Set up instructions

Remove rear vent cap from back, remove burner and add Gas Burner.

Ensure that the Gas Burner is oriented with the logo facing upwards.

Remove chimney, add chimney cap in its place

## Lighting

Push in and slowly turn the control knob anticlockwise until you hear a click and the burner ignites. Continue to push and hold in the knob for 5 seconds before releasing.

Adjust the flame output of your Gas Burner using the control knob.

*If the gas does not light please refer to your Gas Burner manual.*

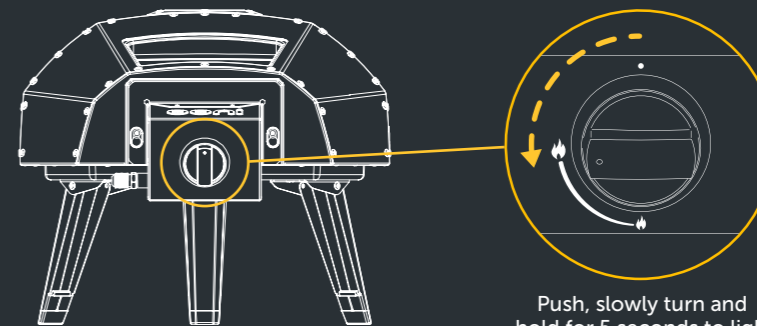

Push, slowly turn and hold for 5 seconds to light

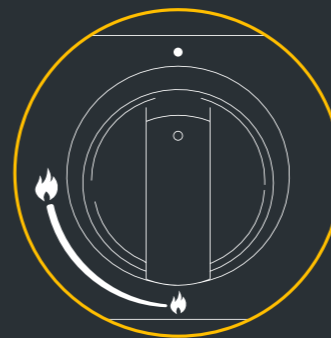

Off

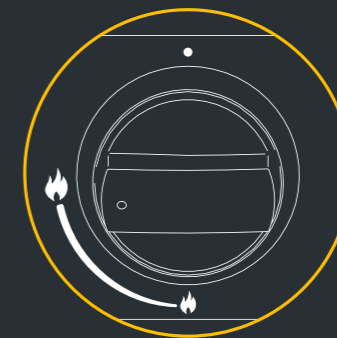

High

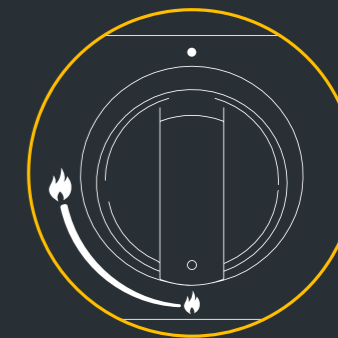

Low

\*\* Gas Burner available at [ooni.com](http://ooni.com). Region dependent.

# Flame Management

What are you looking for when cooking with fire? Neapolitan-style pizza needs real flame to cook a pizza in 60 seconds.



This is the type of fire to aim for for Neapolitan-style pizza; it's the result of fuel management. You'll see this when fuel is given time to burn through properly and there is enough room for airflow through the grate.



Ooni Karu is not ready to cook a 60-second pizza when the fuel tray looks like this. If this is your scenario, gradually build up a flame using smaller pieces of kindling, allowing for good airflow through the grate. Always give new fuel enough time to burn properly before you start cooking.

If you are cooking with charcoal, the flames will be smaller. Add a small piece of kindling 2 or 3 minutes before you bake your pizza to achieve the flames as in image 1.

# Top tips for making great pizza

1. Use high quality 00 flour and fresh ingredients. 00 flour is a finely milled Italian style of flour and it is the gold standard for pizza dough.
2. Stretch out a nice, thin base and leave a centimetre-wide space to form a crust that will puff up under the intense heat of the flames.
3. Using your Ooni Infrared thermometer, aim for at least 752°F (400°C) in the centre of your stone baking board before you launch a pizza into the oven.
4. Rotate your pizza every 20-30 seconds to achieve an even bake on your crusts and toppings.
5. Top up your fuel little and often and allow new fuel to burn for a couple of minutes before adding food.
6. Check out the recipes and guides available on our website and subscribe to our YouTube channel for inspiration and top tips.



## Top tips for launching pizza

Get your peel, dough and ingredients to room temperature. Cold dough will spring back on itself and stick; warm dough will stretch too far and tear. If you stretch your pizza on a warm peel, the dough will start to sweat, which will cause it to stick.

Flour your hands and the surface you are working on before you begin stretching.

Check for holes in the pizza base before adding toppings - If sauce gets between the dough and peel it will have a gluey effect and your dough will stick.

Before you add any toppings - stop and shake the peel to check that your dough is moving freely. If it's stuck, pick it up and add more flour to the peel. You have to do this before you add toppings!

Keep your toppings light. Heavy ingredients will weigh down your dough and make it harder to lift off of the peel.



Work swiftly - there's no need to rush but remember dough that rests on the peel for too long will be more likely to stick. Get your pizza ready when both you and Ooni Karu are ready to cook.

If your pizza does stick you can use what we call the *hovercraft technique* (see below). Lift up the edge of your dough at one side and gently blow air underneath the base. This will create air pockets and will spread flour to the areas that are sticking.



# Classic Pizza Dough

Flour, salt, water and yeast – what do these simple ingredients have in common? They come together to create the perfect foundation for any good pizza!

This recipe is an excerpt from our new cookbook, *Ooni: Cooking with Fire*, and the go-to pizza dough recipe for everyone at Ooni HQ.

Ingredient	Weight	Qty / Vol
Type '00' flour (or strong white)	500g	4½ cups
Water	300g	1¼ cups
Salt	10g	2 tsp
Fresh yeast*	7g	¼ oz

\*if unavailable, use ½ tsp (3g) active dried yeast or ¼ tsp (2g) instant dried yeast

## Method

Place two-thirds of the water in a large bowl. In a saucepan or microwave, bring the other third of water to boil, then add it to the cold water in the bowl. This creates the correct temperature for activating yeast. Whisk the salt and yeast into the warm water.

### If mixing by hand:

Place the flour in a large bowl and pour the yeast mixture into it. Stir with a wooden spoon until a dough starts to form. Continue mixing by hand until the dough comes together in a ball. Turn it onto a lightly floured surface and knead with both hands for about 10 minutes, until it is firm and stretchy. Return the dough to the bowl. Cover with plastic wrap and leave to rise in a warm place for 1-2 hours.

### If mixing with a mixer:

Fit the mixer with the dough hook and place the flour in the mixer bowl. Turn the machine on at a low speed and gradually add the yeast mixture to the flour. Once combined, leave the dough to keep mixing to at the same speed for 5-10 minutes, or until the dough is firm and stretchy. Cover the dough with plastic wrap and leave to rise in a warm place for 1-2 hours.

When the dough has roughly doubled in size, divide it into 3 or 5 equal pieces, depending on what size you want your pizzas to be (either 12 inches or 16 inches wide). Place each piece of dough in a separate bowl or tray, cover with plastic wrap and leave to rise for another 20 minutes, or until doubled in size.





# Classic Pizza Sauce

Simplicity at its finest, our super easy, no-nonsense Classic Pizza Sauce creates the perfect complement for layering up your pizza toppings of choice.

Made using a stovetop (hob) rather than in your Ooni, this recipe is an excerpt from our cookbook, *Ooni: Cooking with Fire*. Choosing good quality tomatoes will make a difference to the flavor of your sauce - we like to go for canned San Marzano tomatoes, which are the traditional choice for Neapolitan pizzas.

Ingredient	Weight	Qty / Vol
Canned tomatoes	800g	4 cups
Olive oil	30g	2 tbsp
Sugar	10g	2 tsp
Salt	4g	1 tsp
2 garlic cloves, crushed or finely chopped		
Handful of basil leaves, roughly chopped		
Pinch of freshly ground black pepper		

## Method

Place the oil in a pan over a medium heat. When warm, add the garlic and fry until softened but not brown.

Add all the remaining ingredients, then simmer on a low heat for 20 minutes, or until the flavor has deepened and the sauce has thickened slightly.

This sauce can be used straight away, or placed in an airtight container and stored in the fridge for up to a week, ready to be used as required.



# Pizza Margherita

The classic pizza Margherita is a simple yet delicious recipe; the perfect starting point if you're new to the world of wood-firing!

All Ooni pizza chefs should be able to master this one with just a little bit of practice. And if you haven't yet, we're here to help you along the way.

## Ingredient

Ooni Classic Dough

Ooni Classic Sauce

Fresh mozzarella

Basil leaves

## Method

Light up your Ooni, then get ready to prepare your pizza while it heats up.

Using a small amount of flour, dust your Ooni pizza peel. Stretch the pizza dough ball out to 12" and lay it out on your pizza peel. Using a large spoon or ladle, spread the sauce evenly across the pizza dough base.

Next, add the cheese and slide the pizza into the pizza oven.

Slide the pizza off the peel and into your Ooni pizza oven, making sure to rotate the pizza regularly.

Once cooked, remove the pizza from the oven. Add a small handful of fresh basil to garnish.



## Rosemary Chicken with Roasted Onions

Moist and tender on the inside, deliciously crispy on the outside. Nothing can compare to the magic of cast iron when it comes to cooking chicken – conducting high heats, our Cast Iron Series locks in flavor while perfectly searing cuts of meat.

Cooked in the Skillet, our herb-infused Rosemary Chicken with Roasted Onions is super simple to prepare and cook.

### Ingredients

- 5 chicken thighs, skin on
- 1 large red onion, cut into wedges
- 2 large sprigs rosemary
- 3 tablespoons (50ml) olive oil
- 3.5oz (100g) butter
- 1 tablespoon (15g) salt
- ½ red chilli - finely sliced to garnish

### Method

Pat the chicken dry with paper towels and season with salt.

Preheat your Ooni Pro or Ooni 3 to a medium-high heat. If using a conventional oven, preheat to 360°F (180°C). You can check the temperature inside your Ooni quickly and easily using the Ooni Infrared Thermometer.

Put the olive oil in your Skillet and place the skillet into your oven. Note that the Skillet handle will become very hot and should be handled with care – remember to use Ooni Gloves or a dry dish towel and to place the skillet on a heat-proof surface.

Remove the hot skillet from the oven. Place the chicken skin side down onto the hot Skillet, and leave the chicken to sizzle untouched for 3 minutes, or until the skin starts to brown.

Once golden brown, flip the chicken over. Add the butter to the skillet and use a spoon to baste the chicken with the melted butter. Add the rosemary sprigs and onion to the skillet.

Return your skillet to the oven to continue cooking the chicken until the chicken juices run clear.



# Care instructions

## Where should I store Ooni Karu?

Ooni Karu is built to last and you can leave it outdoors all year long. You can use the Ooni Karu Carry Cover to keep it safe from the elements.

We do recommend that you store Ooni Karu indoors for extended periods without use and to protect it from harsh weather conditions.

## How do I clean Ooni Karu?

A run at top temperatures will do the hard work for you, burning off any excess flour or remnants of food. Always give Ooni Karu time to cool completely before cleaning and never expose warm parts to moisture. You can wipe down the inside with a dry paper towel if you need to.

When cool, the outside of Ooni Karu can be wiped with a damp cloth and dried completely before using a regular stainless steel cleaner to remove any marks or smudges.

## How do I clean the stone baking board?

Your stone baking board can be cleaned by running Ooni Karu at top temperatures.

If you need to remove hard-to-budge debris from the stone, use our Ooni Pizza Oven Brush.

Only cook pizza and dry, bread-based dishes directly on the stone baking board. If you are cooking meat, vegetables or other dishes then use the Ooni Cast Iron Series.

*The stone baking board is not dishwasher safe.*

## How do I extinguish Ooni Karu?

Leave Ooni Karu to burn through any remaining solid fuels and allow it to cool naturally. This can take 60 minutes depending on ambient temperatures.

⚠ Do not apply water to Ooni Karu to extinguish or cool as this can cause damage and personal injury.

💡 Once it has completely cooled, you can flip the stone baking board for the next time you use your Ooni Karu. The top temperatures inside Ooni Karu will naturally clean the underside.



# Troubleshooting

Ooni Karu has been carefully designed to provide exceptional food experiences and we know that you will love using it to cook. Our team have thousands of hours of experience cooking with fire and enjoying delicious pizza. You can reach us at [support@ooni.com](mailto:support@ooni.com) or check out our online FAQs and video guides - we'll be happy to help.

## I am seeing smoke from Ooni Karu

It is perfectly normal for solid fuels to produce some smoke during the initial lighting period. Once Ooni Karu is up to temperature, it will burn cleanly with minimal smoke. Continued smoke is a sign of incomplete combustion and can be caused by reduced airflow or the use of unsuitable fuel.

Remember to follow the lighting steps on pages 16-20 and to top up little and often. An over-full grate can suffocate the flame and cause smoke.

Always store your fuel in a warm, dry environment and use within 6 months. Charcoal and wood that are old may have absorbed moisture and will not burn cleanly or efficiently.

Check that your chimney vent is open and chimney cap is removed which will allow maximum airflow.

## My Ooni Karu has changed colour

Ooni Karu is made from high-quality stainless steel. You may notice some colour changes after repeated heat cycles but this won't affect performance. This change is known as patina; it makes your Ooni Karu unique and we think it looks beautiful! Remember to store your Ooni Karu indoors when it is not in use.

## I can see soot inside Ooni Karu

Soot is natural when burning solid fuels. Excess soot can be wiped down using a dry paper towel or the Ooni Pizza Oven Brush when Ooni Karu has completely cooled. You can reduce the amount of soot through efficient fuel management as described on page 22.

Remember to open the chimney vent fully and remove the chimney cap for optimum airflow and an efficient burn.

## My Ooni Karu is running too hot

Fuel management is the easiest way to reduce the temperature of Ooni Karu. If your Ooni Karu exceeds 932 °F (500 °C), stop adding fuel and remove the hatch until regular temperatures are reached. You can also reduce the flames by closing over the chimney vent (see page 14).

If your stone baking board is too hot, try adding a piece of Ooni cast iron for 30 seconds or so to absorb some of the heat.

## My Ooni Karu is not hot enough

Ooni Karu will preheat from 10 minutes. Add an additional 5-10 minutes to this preheat time if your Ooni Karu is not running hot enough.

If cooking with charcoal or wood, check that your chimney vent is open and the chimney cap is removed for optimum airflow. Before each cook, free the grate of any leftover ash by brushing it down. Only use fuel that is high quality, dry and less than 6 months old.

Keep your door on throughout any charcoal and wood-fired cooks. This helps to keep heat in and allows the chimney to work its magic drawing heat from the grate.

*Note: If your Ooni Karu has been exposed to rain or extreme cold it may take longer to preheat.*

### **My base is overcooked**

We recommend the use of our Ooni Infrared Thermometer for gauging the temperature of your stone baking board. Aim for 752 °F (400 °C) in the middle of the stone for Neapolitan style pizza. Thicker pizza styles will require a lower stone temperature. Some other tips that will prevent overcooking are:

- Reducing your preheat time
- Reducing the amount of flour added to your pizza base
- Using a thin base made using the Classic Ooni Pizza Dough recipe
- Adding enough fuel to provide flames across the top of your pizza while the stone bakes from underneath



If your stone baking board is too hot, try adding a piece of Ooni cast iron for 30 seconds or so to absorb some of the heat.

### **My stone baking board looks dirty**

Your stone baking board may change colour during your cook but this will not affect performance. If you want, you can scrape away any excess flour or food with the Ooni Pizza Oven Brush. Once the stone baking board has completely cooled, you can flip it over for the next time you cook - the high temperatures inside Ooni Karu will naturally clean the underside.

### **My burner grate has changed shape**

Parts of Ooni Karu will regularly reach temperatures of 1000 °F (537 °C) and above. As a result, the appearance of your grate may change but this will not affect performance.

*Replacements are available to order via [ooni.com](https://www.ooni.com).*





## Keep in touch

We love hearing and seeing what you create and cook with your Ooni Karu so keep in touch by tagging your photos with #ooni or #oonified

Follow us and keep up to date with all things Ooni via:



Subscribe to our mailing list at [ooni.com](https://ooni.com) for access to delicious recipes, top tips and exclusive promotions. If you have any questions, queries or comments then you can reach us at [support@ooni.com](mailto:support@ooni.com).



# Everyone deserves great pizza

**ooni**

[ooni.com](https://ooni.com)

© 2019 Ooni

Ooni is a registered trademark of Ooni Ltd.

All rights reserved.

v1.0